

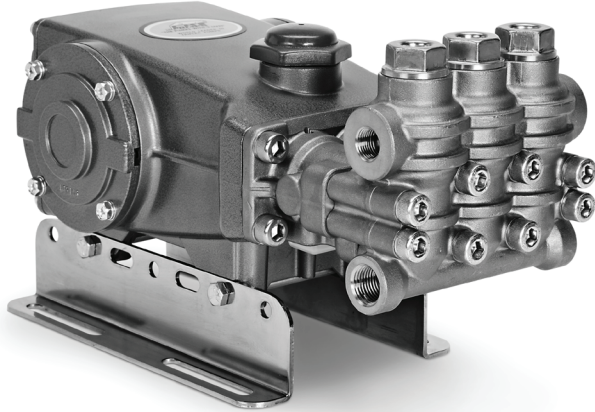

PIJTTERSEN

E-mail : info@pijtersen.nl / info@catpumps.nl
 Internet: www.pijtersen.nl / www.catpumps.nl



Model 700 shown
 (mounting rails sold separately)

FEATURES

- Triplex design delivers high efficiency and low pulsation.
- Durable V-Packings are lubricated and cooled by the liquid being pumped.
- Pre-set Lo-Pressure Seals provide secondary protection against external leaks and require no packing adjustment.
- Special high-density, polished, concentric plungers provide a true wear surface and extended seal life.
- Stacked stainless steel valve design for long life and easy servicing.

**7 Frame
 Plunger Pump**

Model

700

Gearbox

Model

700 G1

SPECIFICATIONS

U.S. Measure

Metric Measure

Flow	4.5 gpm	(17 lpm)
Pressure Range	100 to 5000 psi	(7 to 345 bar)
Inlet Pressure Range	Flooded to 60 psi	(Flooded to 4 bar)
RPM	1700 rpm	(1700 rpm)
Engine RPM (700G1)	3465 rpm	(3465 rpm)
Bore	0.551"	(14 mm)
Stroke	0.945"	(24 mm)
Crankcase Capacity	25 oz.	(0.75 l)
Maximum Liquid Temperature	160°F	(71°C)
Above 130°F call CAT PUMPS for inlet conditions and elastomer recommendations.		
Inlet Ports (2)	1/2" NPTF	(1/2" NPTF)
Discharge Ports (2)	3/8" NPTF	(3/8" NPTF)
Shaft Diameter - Single End	0.945"	(24 mm)
Weight w/o Gearbox	28.45 lbs.	(12.9 kg)
Dimensions	14.04 x 9.25 x 6.47"	(356.6 x 235 x 164 mm)
Dimensions w/Gearbox ...	14.04 x 10.76 x 6.53"	(356.6 x 273 x 166 mm)
See Gearbox Data Sheet for additional information.		

ELECTRIC HORSEPOWER REQUIREMENTS

FLOW		PRESSURE				MOTOR PULLEY SIZE	
		psi 3000	psi 3500	psi 4000	psi 5000	Using 1725 RPM Motor & Std. Pump Pulley O.D.	
U.S. gpm	lpm	bar 210	bar 245	bar 275	bar 345	rpm	Pulley O.D.
4.0	15	8.2	9.6	11.0	13.7	1511	8.5
4.5	17	9.3	10.8	12.3	15.4	1700	9.5
4.5	17	9.3	10.8	12.3	15.4	1700	Gearbox

DETERMINING THE PUMP R.P.M.	<u>Rated gpm</u>	=	<u>"Desired" gpm</u>
	<u>Rated rpm</u>		<u>"Desired" rpm</u>
DETERMINING THE REQUIRED H.P.	<u>gpm x psi</u>	=	Electric Brake
	1460		H. P. Required
DETERMINING MOTOR PULLEY SIZE	<u>Motor Pulley O.D.</u>	=	<u>Pump Pulley O.D.</u>
	<u>Pump rpm</u>		<u>Motor rpm</u>

⚠ CAUTIONS AND WARNINGS

All High Pressure Systems require a primary pressure regulating device (i.e. regulator, unloader) and a secondary pressure relief device (i.e. pop-off valve, relief valve). Failure to install such relief devices could result in personal injury or damage to pump or property. CAT PUMPS does not assume any liability or responsibility for the operation of a customer's high pressure system.

Read all CAUTIONS and WARNINGS before commencing service or operation of any high pressure system. The CAUTIONS and WARNINGS are included in each service manual and with each Accessory Data sheet. CAUTIONS and WARNINGS can also be viewed online at www.catpumps.com/cautions-warnings or can be requested directly from CAT PUMPS.

WARRANTY

View the Limited Warranty on-line at www.catpumps.com/warranty.

See complete Drive Packages [Incls: Pulleys, Belts, Hubs, Key] Tech Bulletin 003. Refer to pump **Service Manual** for repair procedure and additional technical information.

PARTS LIST

ITEM	P/N	MATL	DESCRIPTION	QTY
2	30067	STL	Key (M8x7.5x25)	1
5	125824	STCP R	Screw, HHC Sems (M6x16)	8
8	43223	AL	Cover, Bearing	1
9	815280	FBR	Shim, Split, 2 Pc.	1
10	12393	NBR	O-Ring, Bearing Cover	2
11	43222	NBR	Seal, Oil, Crankshaft - 70D	1
15	43221	STL	Bearing, Roller	2
20	48863	TNM	Rod, Connecting	3
25	119234	FCM	Crankshaft, Single End	1
	46554	FCM	Crankshaft, Single End (Gearbox Only)	1
30	44948	AL	Cover, Blind Bearing	1
31	828710	—	Protector, Oil Cap w/Foam Gasket	1
32	44666	RTP	Cap, Oil Filler, Domed	1
33	14177	NBR	O-Ring, Oil Filler Cap - 70D	1
37	92241	—	Gauge, Oil, Bubble w/Gasket - 80D	1
38	44428	NBR	Gasket, Flat, Oil Gauge - 80D	1
40	125824	STCP R	Screw, HHC Sems (M6x16)	4
48	25625	STCP	Plug, Drain (1/4"x19BSP)	1
49	23170	NBR	O-Ring, Drain Plug - 70D	1
50	127701	AL	Cover, Rear	1
51	14047	NBR	O-Ring, Rear Cover - 70D	1
53	127698	AL	Crankcase w/Guide Pins	1
54	27488	S	Pin, Guide	2
56	43240	POP	Pan, Oil	1
64	43237	CM	Pin, Crosshead	3
65	49892	SZZ	Rod, Plunger	3
69	126589	STCP R	Washer, Oil Seal	3
70	43228	NBR	Seal, Oil, Crankcase	3
75	43328	S	Slinger, Barrier	3
88	45697	S	Washer, Keyhole (M18x10)	3
90	45890	CC	Plunger (M14x72)	3
95	126558	STCP R	Stud, Plunger Retainer (M6x64.5)	3
96	43235	PTFE	Back-up-Ring, Plunger Retainer	3
97	17399	NBR	O-Ring, Plunger Retainer - 80D	3
	14160	FPM	O-Ring, Plunger Retainer - 80D	3
98	45891	CU	Gasket, Plunger Retainer	3
99	46504	S	Retainer, Plunger (M6)	3
100	45689	PVDF	Retainer, Seal, 2-Pc (See Tech Bulletin 105)	3
	43571	—	Wick, Long Tab	3
106	45188	NBR	Seal, LPS w/S-Spg	3
	701790	SFTA	Seal, LPS w/NIH-Spg	3
110	49797	BB	Manifold, Inlet	1
112	11343	NBR	O-Ring, Inlet Manifold - 70D	3
	14186	FPM	O-Ring, Inlet Manifold - 70D	3
117	49679	S	Screw, HSH (M10x35)	4
118	49680	S	Washer	4
121	14200	NBR	O-Ring, V-Packing Spacer - 70D	3
	11719	FPM	O-Ring, V-Packing Spacer	3
122	49840	PTFE	Back-up-Ring, V-Packing Spacer	3
123	49839	NBR	O-Ring, V-Packing Spacer - 90D	3
	11686	FPM	O-Ring, V-Packing Spacer - 80D	3
124	49838	BB	Spacer, V-Packing	3
126	45896	BB	Adapter, Female	3
127	45895	SNG	V-Packing	9
	701911	SFTA	V-Packing	9
128	46567	BB	Adapter, Male	3
159	49861	PTFE	Back-up-Ring, Inlet Valve Seat	3
160	11346	NBR	O-Ring, Inlet Valve Seat - 70D	3
	11376	FPM	O-Ring, Inlet Valve Seat - 70D	3
161	49846	S	Seat, Inlet	3
162	49844	PTFE	Back-up-Ring, Discharge Valve Seat	3
163	49845	NBR	O-Ring, Discharge Valve Seat - 70D	3
	49894	FPM	O-Ring, Discharge Valve Seat - 70D	3
164	49843	S	Seat, Discharge	3
165	49847	PVDF	Retainer, Spring, Inlet	3
166	46562	S	Valve	6
167	43750	S	Spring	6
168	44565	PVDF	Retainer, Spring, Discharge	3
172	49382	NBR	O-Ring, Valve Plug -90D	3
	49897	FPM	O-Ring, Valve Plug -90D	3
173	49850	PTFE	Back-up-Ring, Valve Plug	3
174	49849	BB	Plug, Valve	3
185	49798	BB	Head, Manifold (M10)	1
188	49852	S	Screw, HSH (M10x65)	8
255	30243	STZP	Mount, Direct	1
260	30645	STZP R	Assy, Angle Rail A	1
	30611	STZP R	Assy, Angle Rail B	1

EXPLODED VIEW

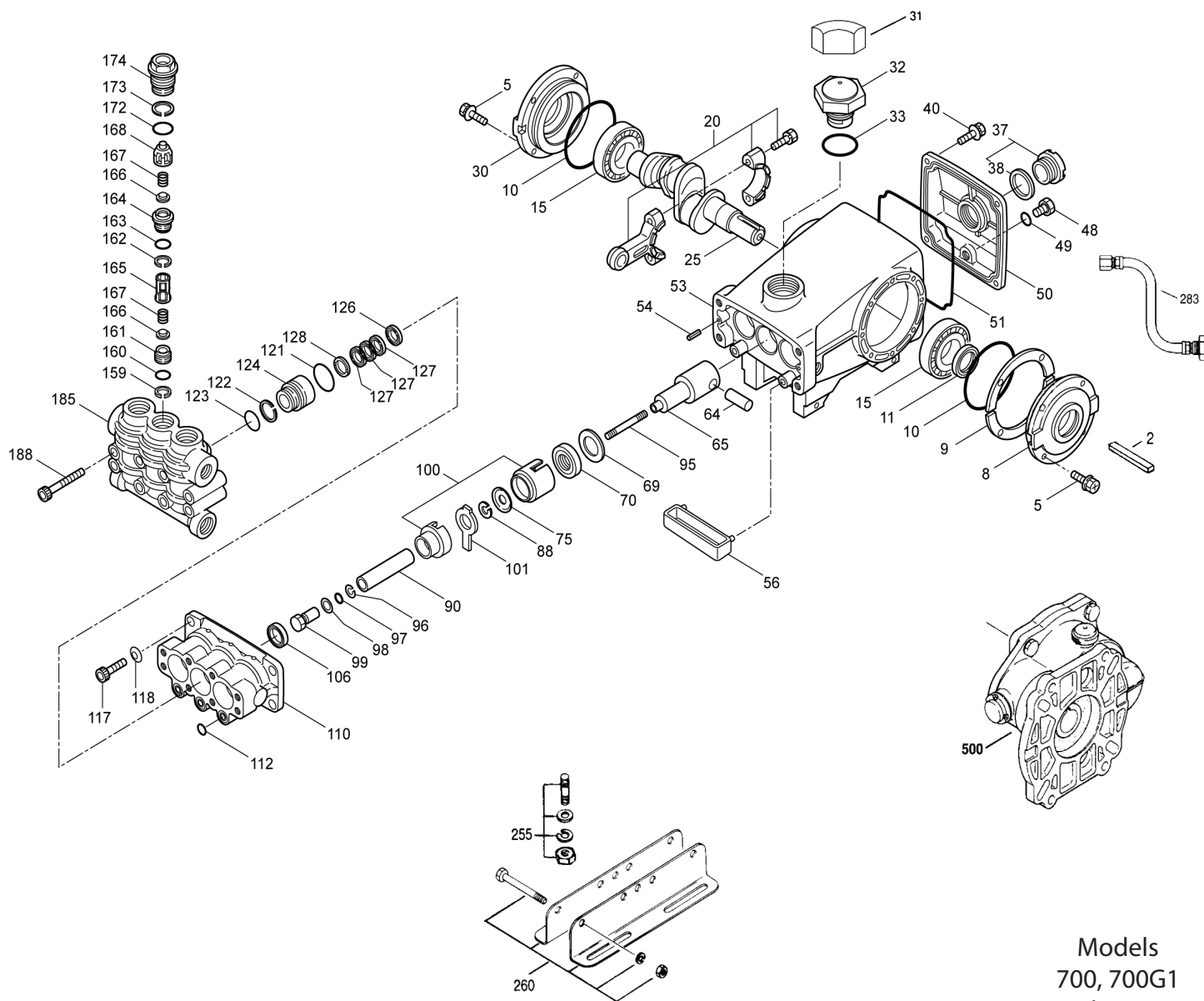

Models
700, 700G1
July 2012

ITEM	P/N	MATL	DESCRIPTION	QTY
265	30660	—	Mount Assy (Incls: 30645, 33000, 30206, 43256, 30067)	1
269	30206	F	Pulley (10") AB [See Tech Bulletin 003]	1
274	33000	STL	Hub (M24), H Series [See Tech Bulletin 003]	1
283	34334	—	Kit, Oil Drain (3/8"x 24") (See individual Data Sheet)	1
	76334	—	Kit, Oil Indicator (3/8"x 24") (See individual Data Sheet)	1
299	818537	FBB	Head, Complete	1
300	76079	NBR	Kit, Seal (Incls: 97,101,106,112,121,122,123,127)	1
	76032	FPM	Kit, Seal (Incls: 97,101,106,112,121,122,123,127)	1
310	76081	NBR	Kit, Valve (Incls: 159,160,161,162,163,164,165,166,167,168,172,173)	1
	76034	FPM	Kit, Valve (Incls: 159,160,161,162,163,164,165,166,167,168,172,173)	1
350	30696	STZP	Pliers, Reverse	1
351	43257	STZP	Tool, Seal Case Removal	1
352	44050	STZP	Tool, Oil Gauge Removal	1
500	8071	—	Gearbox, 1" (See 8051-8078 Data Sheet)	1
—	6107	—	Oil, Bottle (21 oz.) ISO 68 Hydraulic (Fill to specified crankcase capacity prior to start-up)	1 - 2

Italics are optional items. [] Date of latest production change.

R Components comply with RoHS Directive. Refer to Tech Bulletins 002, 003, 024, 036, 043, 051, 054, 061, 064, 067, 074, 077, 083 and 105 for additional information.

MATERIAL CODES (Not Part of Part Number): AL=Aluminum BB=Brass CC=Ceramic CM=Chrome-Moly CU=Copper F=Cast Iron FBR=Fiber

FCM=Forged Chrome-moly FPM=Fluorocarbon NBR=Medium Nitrile (Buna-N) POP=Polypropylene PTFE=Pure Polytetrafluoroethylene

PVDF=Polyvinylidene RTP=Reinforced Composite S=304SS SFTA=Special Blend PTFE Tan SNG=Special Blend (Buna) STL=Steel

STCP=Steel/Chrome Plated STZP=Steel/Zinc Plated SZZ=3044SS/Zamak TNM=Special High Strength

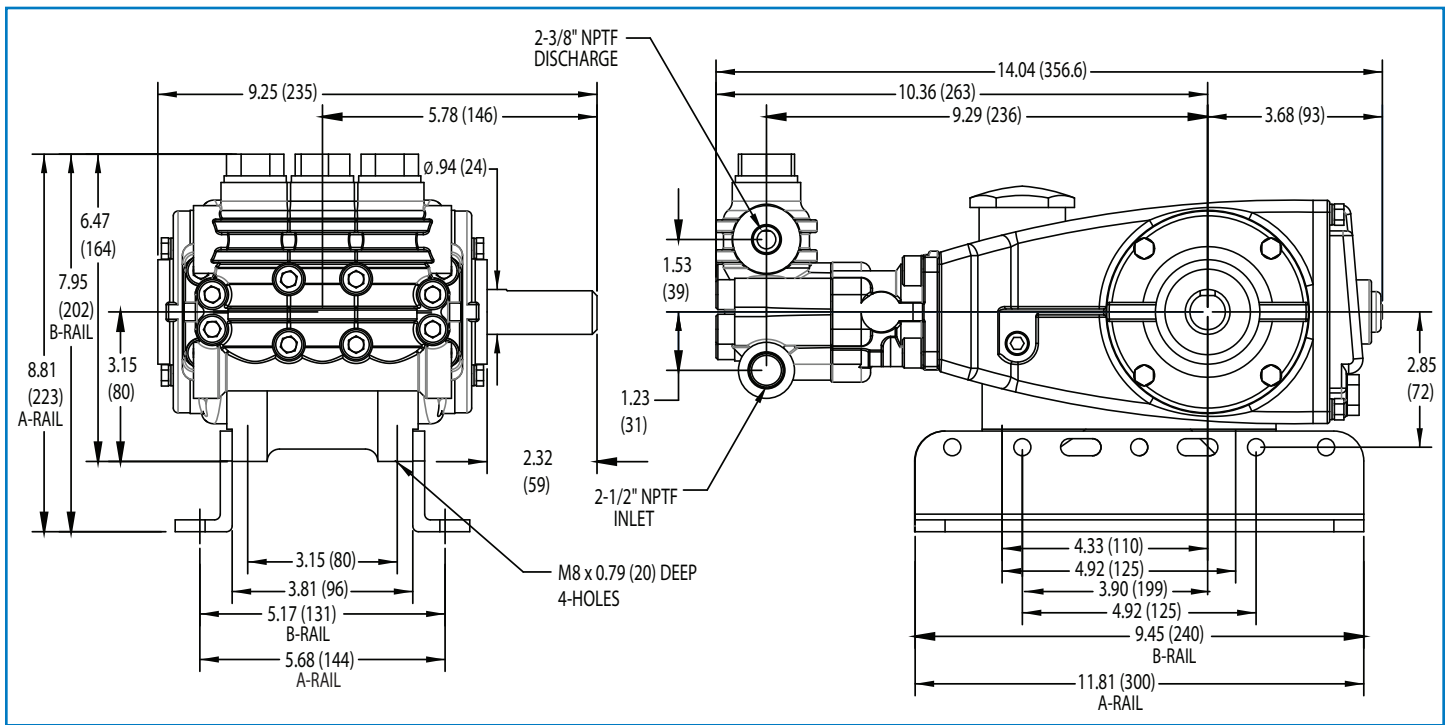

Model 700



PIJTTERSEN

Pijtersen B.V.
 Stavangerweg 14A
 9723 JC GRONINGEN
 THE NETHERLANDS

Tel.: +31 (0)50-8200963

E-mail : info@pijtersen.nl / info@catpumps.nl

Internet: www.pijtersen.nl / www.catpumps.nl



The Pumps with Nine Lives

PN 993466 Rev A 7/12 12307